

Development, Anatomy and Physiology of the Eye

The word **perspective** comes from the Latin *per-* “through” and *specere* “look at”. Last week we discussed vision from a **historical perspective** in order to understand how Johannes Kepler, René Descartes and Bishop Berkeley discovered the importance of the mind in effecting vision. Next we discussed image formation from a **geometrical and analytical perspective** in order to understand how Euclid, Ptolemy, Alhazen, Kepler, Snel and Descartes discovered how images were formed by reflecting and refracting elements, including metallic mirrors, glass lenses, and the proteinaceous cornea and crystalline lens of our eye. Today we will talk about the eye and its connections with the brain from the perspective of development, anatomy and physiology.

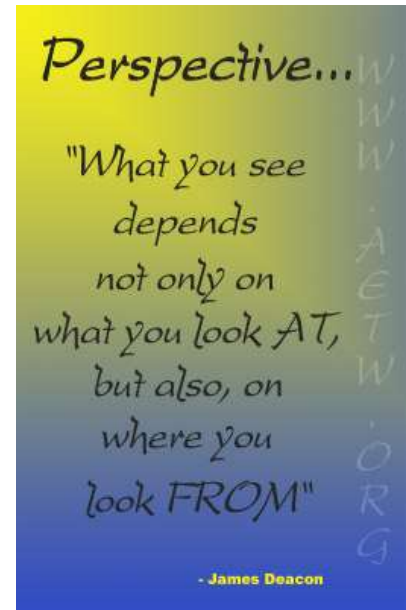

Our eyes develop to a large extent while we are in the womb from the fourth to the tenth week (28-70 days) following conception:

(https://embryology.med.unsw.edu.au/embryology/index.php/Carnegie_stage_13).

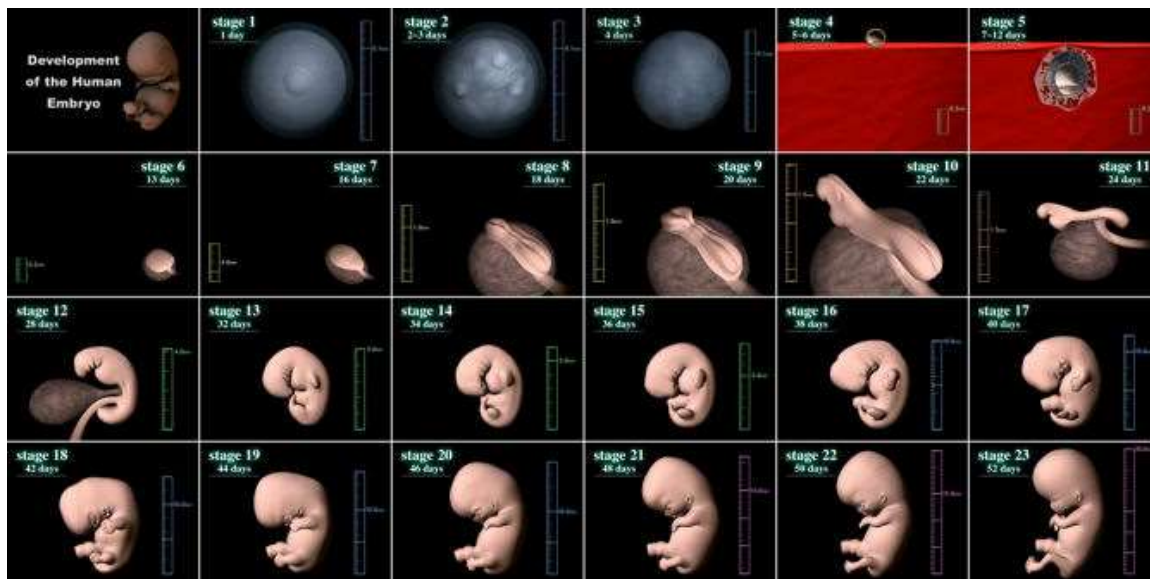

Following conception, the fertilized egg divides to form tissues that will connect the embryo to the mother, yolk cells that will give rise to the germ cells, and stem cells. The **embryonic stem cells** give rise to the three embryonic tissues. Our eyes have their origin in these three embryonic tissues: the lens and the cornea as well as the optic nerve, the retina and the epithelial layers of the iris and ciliary body are derived from the **ectoderm**, and the rest is derived from the **mesoderm**.

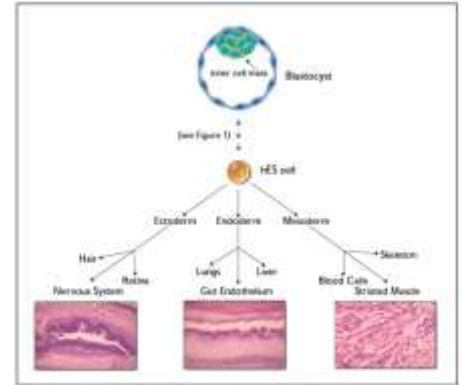
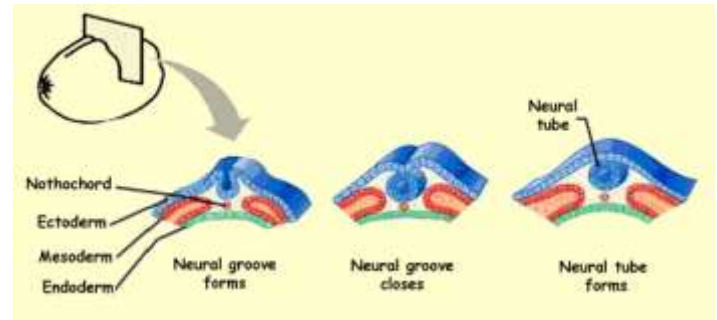
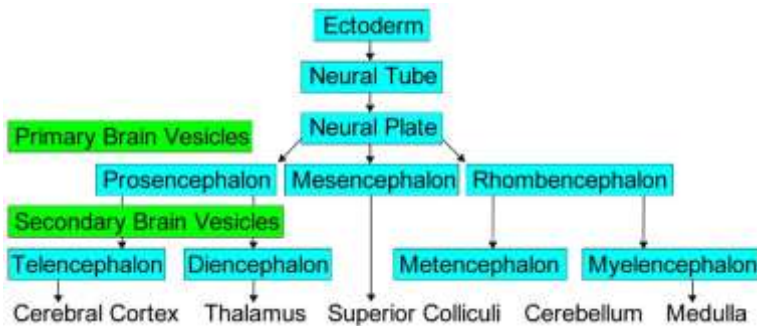
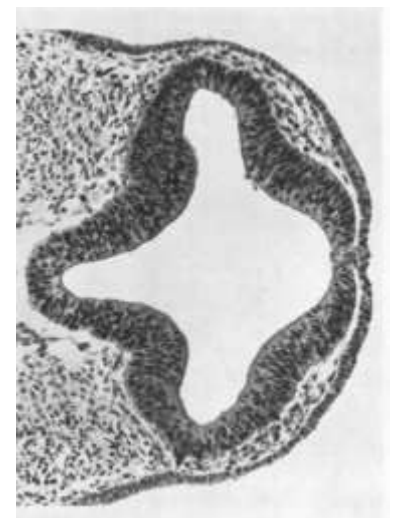
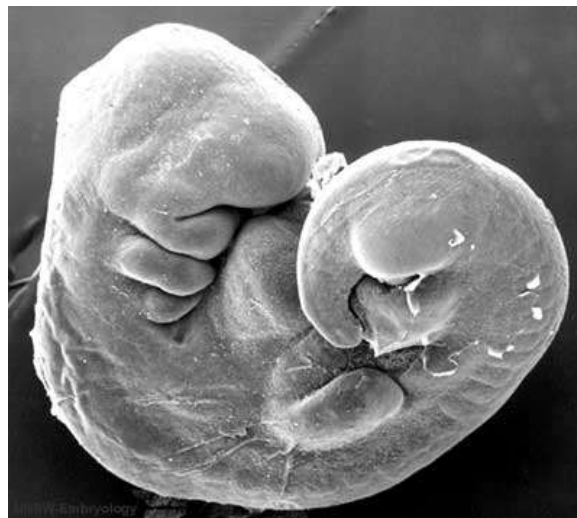

Figure 2: Differentiation of hES Cells into Three Germ Layers



Approximately **four weeks** (28 days) after conception, the **forebrain**, which is derived from the **ectoderm** and from which the optic nerve, the retina, and the epithelia of the ciliary body develop, pushes its way into the



surrounding loosely-associated cells known as the **mesenchyme**, which is derived from the **mesoderm**, to form the **optic vesicles**.

During the **fifth week** (35 days), as each optic vesicle grows, it makes contact with the thickened surface of the **ectoderm** known as the **lens placode** causing it to

differentiate into the **crystalline lens** of the eye instead of skin epidermal cells. The contact is also accompanied by invagination of the **optic vesicle** into an **optic cup** where the lumen of the optic vesicle is reduced to a slit. The **inner layer** of the optic cup develops into the **neural retina** and the **outer layer** develops into the **retinal pigmented epithelium**.

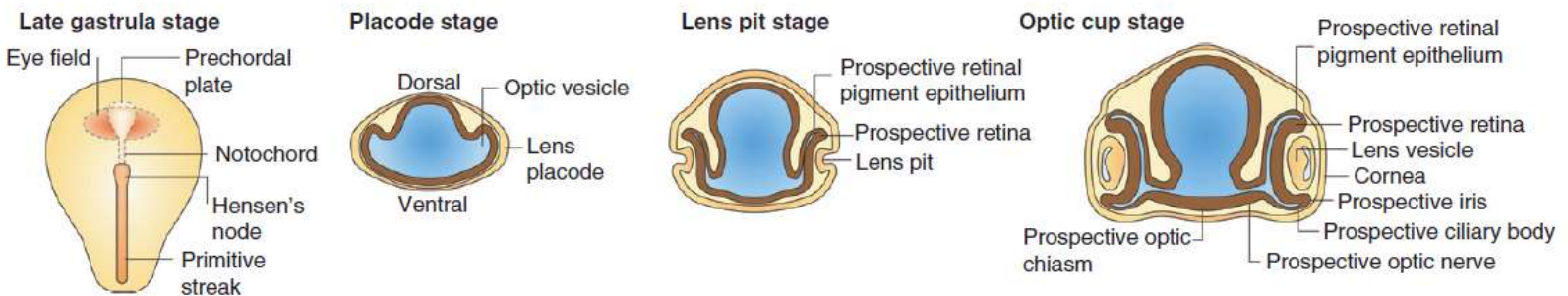
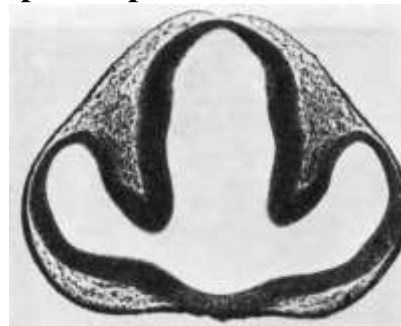
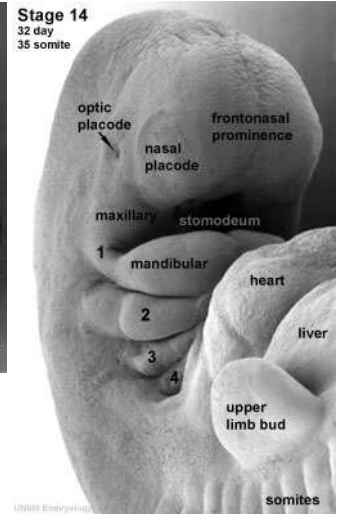
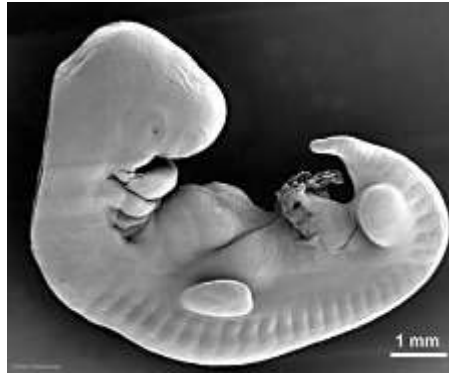

By the **sixth week** (42 days), the **crystalline lens** breaks free within the optic cup where it will continue to develop.



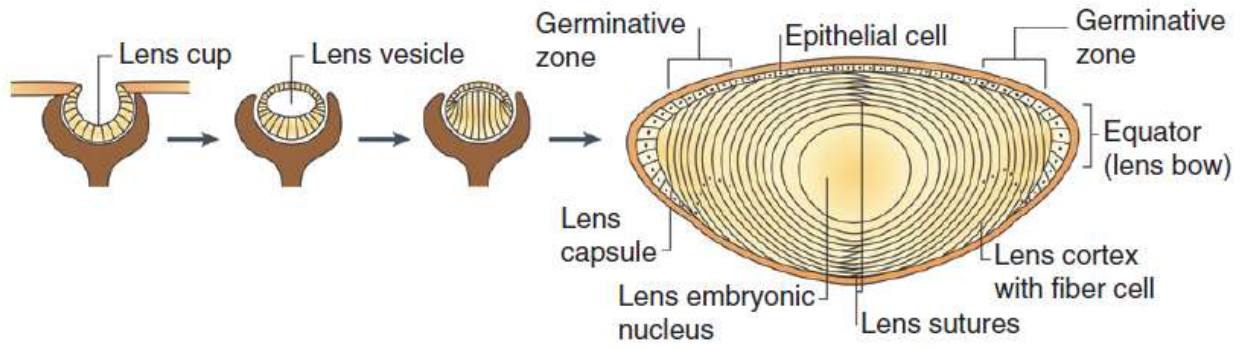

By the **seventh week (49 days)**, the **outer layer of the cornea** differentiates from the ectoderm. The mesenchyme surrounding the optic cup differentiates into the **stroma of the cornea**, the **sclera** and the **choroid**.

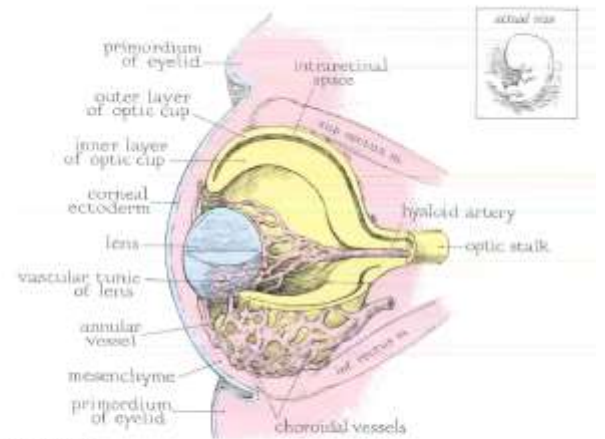
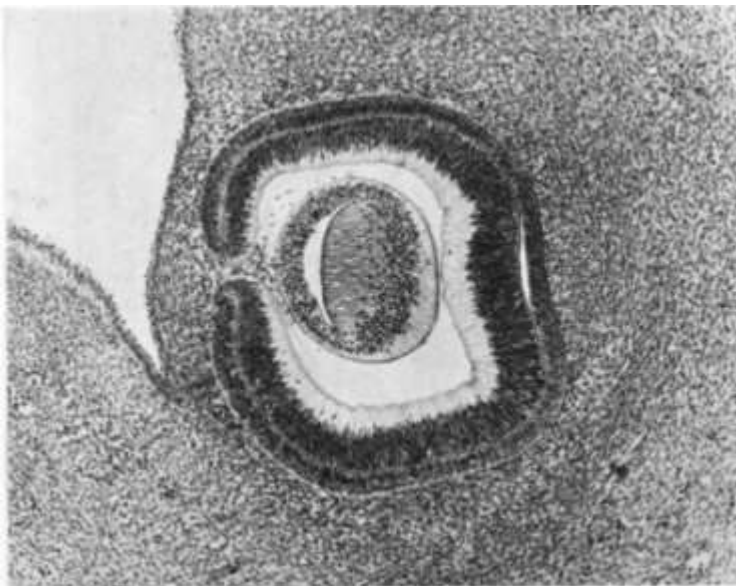
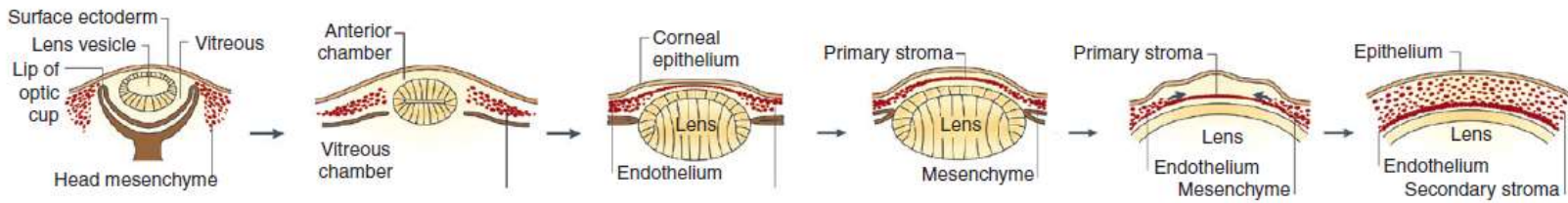
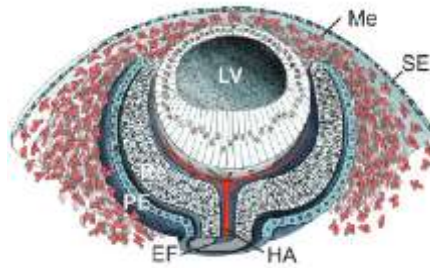

Figure 102, Stage 19
16-18 mm 48 days 7th week
(172, 175, 176, 177, 223)
Section of the eye

While the inner layer of the optic cup develops into the **neural retina**, the leading edge of the optic cup participates in the formation of the epithelial portion of the **iris** and the



ciliary body. While most of the neural retina will differentiate into a layer of **rods and cones**, it will also differentiate into a layer of **bipolar cells** and a layer of **ganglion cells**. Some of the ganglion cells will extend towards the brain and differentiate into the **optic nerve**. We will talk about the retina in detail next week when we talk about color vision.

Hans Spemann (1924) studied eye development and hypothesized that the optic cup acts as an “*organizer of the lens*.” He proved the existence of “organizers” by doing tissue transplants and inducing tissues to

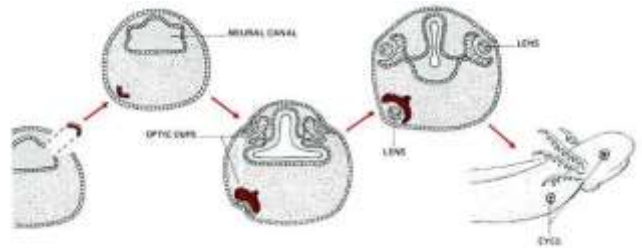

develop into other tissues. Spemann won the Nobel Prize in 1935 for his work (http://www.nobelprize.org/nobel_prizes/medicine/laureates/1935/press.html).

Below is a proposed model of the role of organizers, which are now known as **localized inducing molecules** or **paracrine factors** that may cause the differentiation of the crystalline lens, the retina, and the cornea.

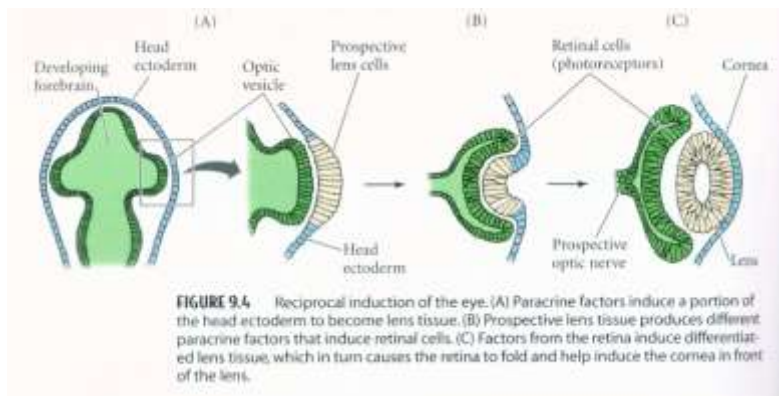

During the **eighth week** (56 days), the **stroma of the iris** differentiates from mesenchyme as the



anterior and posterior spaces on either side of the iris fill with **aqueous humor**. We will talk about the iris in detail next week when we talk about eye color. The **vitreous humor** develops in the space between the crystalline lens and the neural retina. At this stage, the **retinal pigmented epithelium** causes the eyes to be seen as small dark holes on either side of the head.

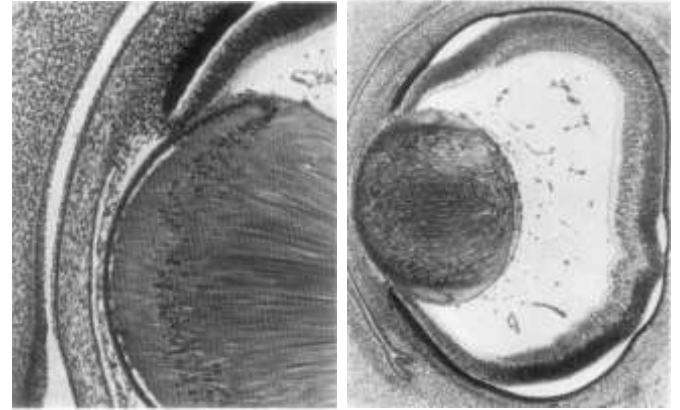

By the **ninth week** (63 days), the **eyelids** are developed. The eyelids will stay closed from the third month until the seventh month (26 weeks).

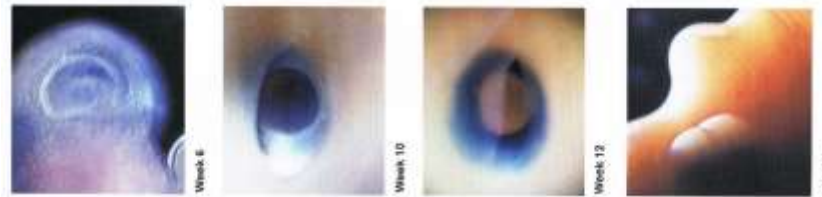

By the **tenth week** (70 days), although still developing, the eye looks very much like an adult eye.

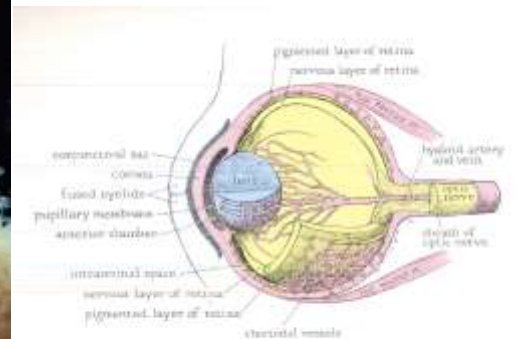

Figure 633. Fetal fetal period.
50 mm. 10 weeks.
(S, U, L2, U7)
Section of the eye

During the **sixteenth week** (4 months), the retina and the neural connections to the brain are still developing. At **six and one-half months**, the eyes are still sealed-shut.



African American, Hispanic and Asian babies are usually, although not always, born with brown eyes while Caucasian babies are usually born with blue eyes. Babies do not always come out the way parents expect: Richie Lopez



was born without eyes. His parents hope that he will get an eye transplant or eyes grown from stem cells.



<http://www.cnn.com/videos/tv/2015/01/27/dnt-az-baby-born-without-eyes.ktvk>

When a baby is born the **rods** are fully developed and the baby has low light **black and white scotopic vision**. Approximately three months later, the **cones** form and the baby also has **photopic color vision**.

The **retina** is derived from the optic cup and some consider the retina to be a part of the brain, having been sequestered but not isolated from it early in development. Interestingly, **the retina is only part of brain that is readily visible to us**. It can be viewed with an **ophthalmoscope**.

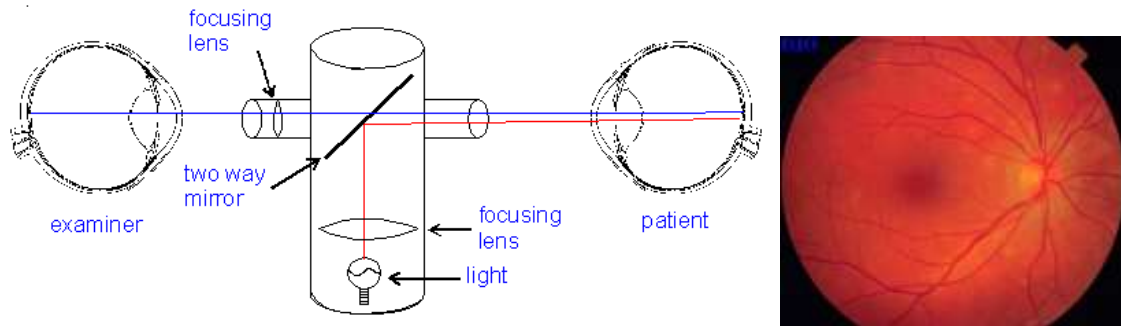

Demonstration: View your classmate's retina with an ophthalmoscope.

The **neural retina** contains the light-sensitive photoreceptor cells, known as **rods** and **cones**. The rods and cones are modified cilia. The rods and cones are on the neural retinal layer closest to the **retinal pigmented layer** and farthest from the external world. The rods are very light sensitive and are involved in dark (**scotopic**) vision while the cones are less light sensitive and are involved in normal color (**photopic**) vision.

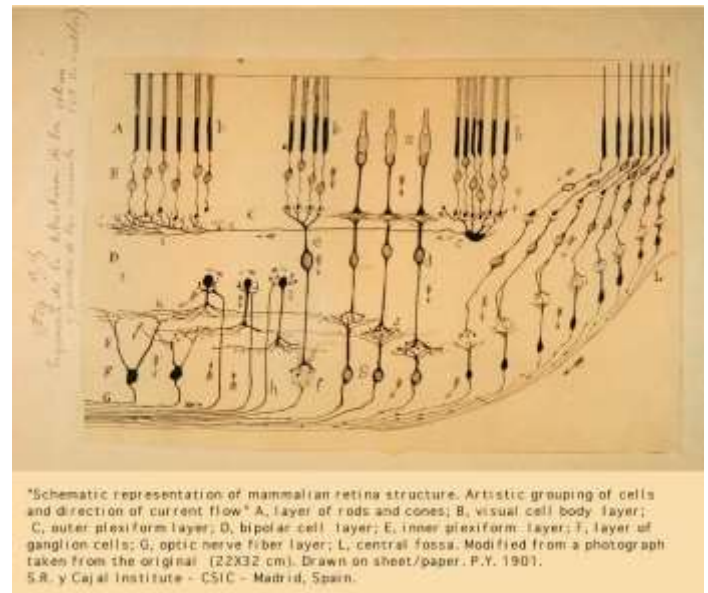

"Schematic representation of mammalian retina structure. Artistic grouping of cells and direction of current flow." A, layer of rods and cones; B, visual cell body layer; C, outer plexiform layer; D, bipolar cell layer; E, inner plexiform layer; F, layer of ganglion cells; G, optic nerve fiber layer; L, central fovea. Modified from a photograph taken from the original (22x32 cm). Drawn on sheet/paper. P.Y. 1901. S.R. y Cajal Institute - CSIC - Madrid, Spain.

Scotopic vision, effected by the rods is more **efficient** in utilizing light at low light intensities than **photopic vision**, effected by cones. Moreover the range of spectral colors utilized by the rods is blue-shifted relative to the range of spectral colors utilized by the cones. Perhaps this is why objects illuminated by moonlight look black and bluish-white.

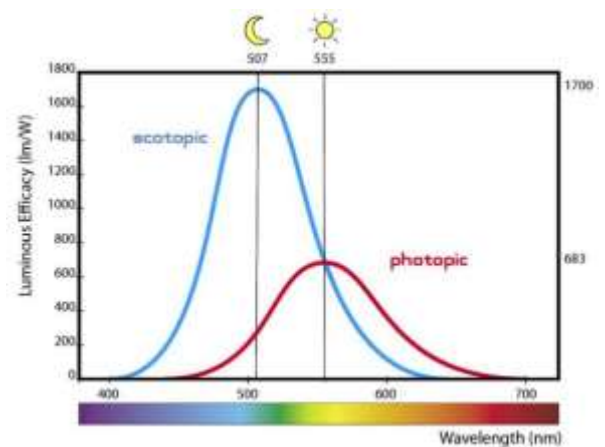

Remember from the Pulfrich pendulum effect, that when we use our scotopic vision, we see things “**in the past.**” Night lights in baseball stadiums allow players to play with their photopic vision, so they see, and catch or hit the ball “**in the present.**”

The rods and cones are connected to **bipolar cells** which in turn are connected to **retinal ganglion cells**. The retinal ganglion cells are in the layer of the retina closest to the external world. The axons of the retinal ganglia pass through the retina at the **optic disc** to connect with the optic nerve. Since two cells cannot be in the same place at the same time, this precludes the photoreceptor cells from being in the **optic disc**, thus creating a **blind spot** on the nasal side of the retina.

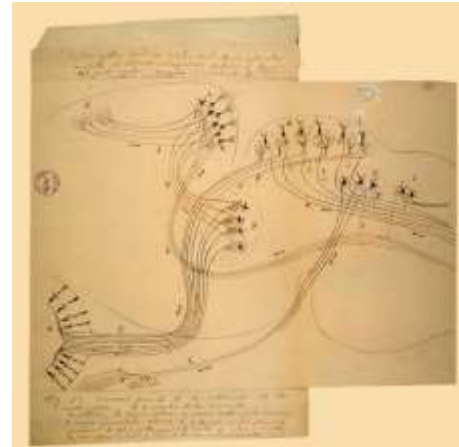

Schematic of the afferent and efferent pathways of the optic centers. A, retina; B, optic nerve; C, fibers from the oculomotor nucleus; D, lateral geniculate nucleus; E, colliculus; F, optic fibers; G, visual cortex; K, central optic pathway; J, pathway of visual association fibers; L, motor pathway arising from the visual cortex; M, superior colliculus; N, oculomotor nucleus; O, collaterals of the cerebral motor pathways. Modified from a photograph taken from the original (34X28cm). Drawn on sheet/paper, P.Y. 1901, S.R. y Cajal Institute - CSIC - Madrid, Spain.

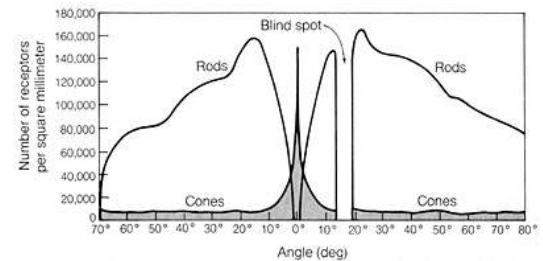
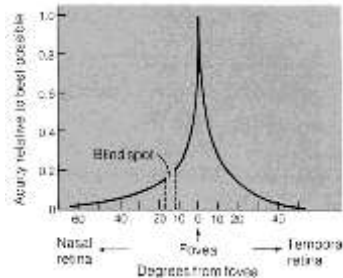
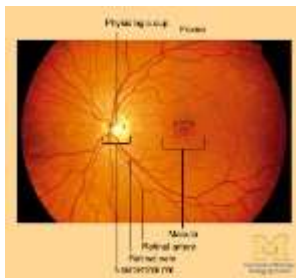

The **rods**, which are used for **scotopic vision**, are located around the periphery of the retina. The most peripheral rods are capable of sensing motion but are not able to produce an image of what is moving. You can tell this by having a friend wave an object such as a **fork or a spoon** at the very edge of your visual field near your ear. You will be able to tell something is moving, and in which direction, but you will have no idea what is moving!

The **cones** that are involved in **photopic color vision** are enriched in the center of the retina known as the **macula**, which is 2.5-3 mm in diameter. The macula is a region of the retina that is rich in retinal ganglion cells as well as cones. The **fovea** is in the center of the **macula**. Just as the **optic disc** excludes the photoreceptor cells, the **fovea** is a depressed area of the retina, about 0.3 mm in diameter, that excludes the bipolar cells and the retinal ganglion cells so that **light travels directly and unhindered through the rest of the neural retina layer to the cones**. Consequently, this region of the retina gives us the greatest **visual acuity**.

Light is hindered from reaching the rods and cones outside the fovea by the bipolar cells and retinal ganglion cells since the rods and cones outside the **fovea** face the retinal pigmented layer instead of the outside world. The rods and cones may face “**backwards**” so that old discs from the photoreceptor cells are **sloughed off to the back** of the retina so that they do not accumulate in the vitreous humor. It has been suggested that the melanin-containing cells are adjacent to the rods and cones to help them chemically restore the light-sensitive visual pigment in the receptors after it has been bleached by light.

Visual acuity is measured with a **Snellen eye chart**, developed by Hermann Snellen in 1862. To measure visual acuity, a person stands 20 feet away from the chart, covers one eye, and reads the letters starting at the top until they get to the line where they can no longer make out the letters. The last line that they can clearly read, gives their visual acuity. A “**standard**” person has a visual acuity of 20/20. Others have better or worse vision. If someone has a visual acuity of 20/200, it means that he or she can see as clearly at 20 feet as a “standard” person can see at 200 feet. Someone with 20/200 vision is legally blind. If someone has a

visual acuity of 20/10, it means that he or she can see clearly at 20 feet what a “standard” person can see at 10 feet.

In angular terms, 20/20 vision is the ability to distinguish between objects that are separated by one minute of arc. The letters on the chart are 0.34 inches tall, which at twenty feet (240 inches) subtend 1.42×10^{-3} radians, which equals 0.08 degrees, which equals 4.9 minutes of arc. That means that the limbs of each letter subtend about one minute of arc. (Note: 2π radians = 360° and $1^\circ = 60$ minutes of arc).

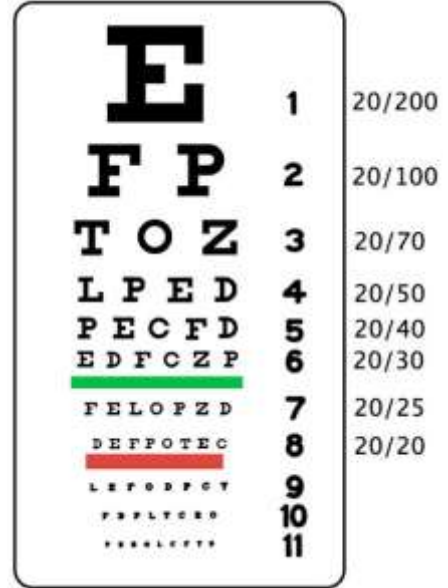

While human visual acuity is excellent, it is not as good as that found in raptors, such as the Bald Eagle.



Image formation by the human eye depends on **two refracting elements**, the **cornea** and the **crystalline lens** that act together to make a **converging lens** with a **variable focal length** and a dioptric power that ranges from 40-53 diopters ($D = \frac{1}{f} = \frac{1}{s_o} + \frac{1}{s_i}$; $s_o = 0.25 \text{ m} - \infty \text{ m}$) in order to project an **in-focus, inverted, real, minified, image** of the outside world on the **retina** (the optical distance between the crystalline lens and the retina is $s_i = 0.025 \text{ m}$). Remember only real images have the **radiant energy** necessary to activate the photoreceptor cells on the retina. The transparent **cornea**, which is the **window of the eye**, is the main refractive element of the eye since there is a great difference in the refractive index between the **cornea** ($n = 1.376$) and air. This cornea is a powerful lens with a dioptric power of about 40 diopters.

The cornea does not have a blood supply because the choroid does not extend into the anterior of the eye. The cornea is nourished by the aqueous humor, which is refilled every 4 hours. Interestingly, the absence of a blood supply means

that **antibodies** made by the immune system of the body *do not* reach the cornea. The absence of any rejection response by the immune system has made **corneal transplants** successful since as early as 1905.

The **crystalline lens** ($n = 1.386-1.406$) is the second refracting element of the eye. When we are young, the crystalline lens can increase the dioptric power of the eye by an additional 13 diopters, giving a total dioptric power of about 53 diopters. The reason that the dioptric power of the crystalline lens, with a refractive index of 1.386-1.406, is less than the dioptric power of the cornea with a smaller refractive index of 1.376, is that the crystalline lens is surrounded by the **aqueous** and **vitreous humors** that have refractive indices 1.336, and 1.337, respectively. The small difference in refractive index, like that of Pyrex glass in Wesson oil, does not allow for much light bending or coarse focusing—only fine focusing.

The crystalline lens is held in place by the **ciliary body** which contains muscles that **contract** in order to increase the curvature of the crystalline lens, which decreases its focal length and increases its dioptric power. The increased dioptric power and decreased focal length allows us to focus near objects on the retina. When the muscles of the ciliary body **relax**, the crystalline lens becomes flatter, the dioptric power decreases, the focal length increases and we can focus distant objects on the retina.

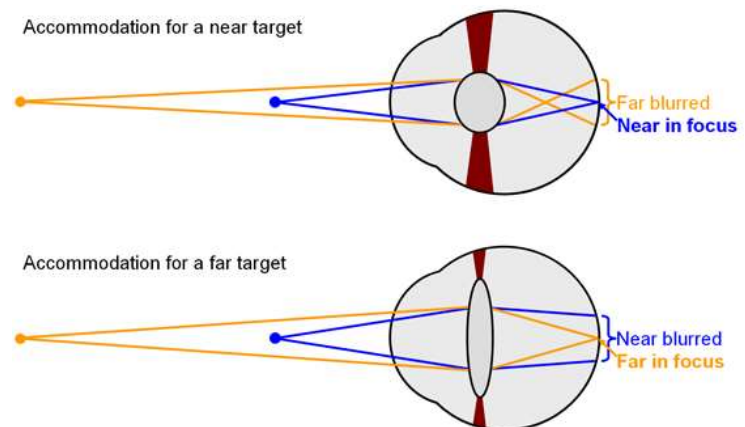

The ciliary muscles act on the crystalline lens through the **zonular fibers** that make up the **suspensory ligament**. The crystalline lens and zonular fibers are both elastic. When the eye is observing **distant objects**, the ciliary muscles are **relaxed**, the zonular fibers are under tension, and the elastic **crystalline lens is maximally flat**, resulting in minimal dioptric power and maximal focal length.

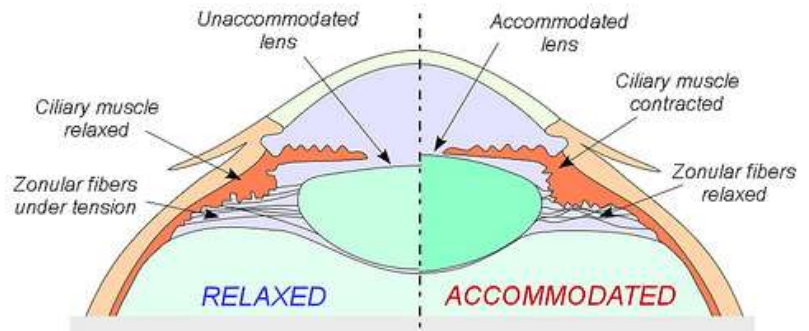

ACCOMMODATION IN THE NORMAL EYE

However, when the eye is observing nearby objects, the ciliary muscle **contracts** and pulls itself forward, releasing the tension on the zonular fibers. This causes the **crystalline lens to become more curved**, and the dioptric power to increase and the focal length to decrease. Note that a camera lens fine-focuses nearby objects by moving the lens closer to the object and farther from the CCD, instead of changing the shape of the lens.

As one ages, the ability to accommodate decreases and the near point moves toward infinity, making it harder and harder to read small print close up (ask your parents).

Demonstration: Keep your glasses on if you wear them. Block one eye. Have someone hold a book and measure the farthest distance between the book and your eye where you can still read the book ($s_o \approx 1$ m). Take the reciprocal of the distance of the far point and add it to the reciprocal of the optical distance between the crystalline lens and the retina ($D = \frac{1}{f} = \frac{1}{s_o} + \frac{1}{0.025}$) to get the dioptric power of the eye. As an example, if $s_o = 1$ m, the dioptric

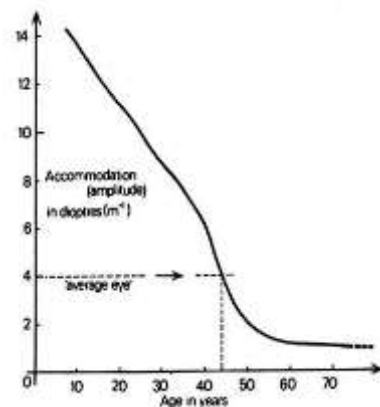

power of the eye is 41 diopters. Move the book closer to you until the words get blurry and measure the closest distance ($s_o \approx 0.08$ m) between the book and your eye where you can still read the book. Take the reciprocal of the distance of the near point and add it to the reciprocal of the optical distance between the crystalline lens and the retina ($D = \frac{1}{f} = \frac{1}{s_o} + \frac{1}{0.025}$) to get the dioptric power of the eye. As an example, if $s_o = 0.08$ m, the dioptric power of the eye is 52.5 diopters. Accommodation range is given by (near point in diopters) – (far point in diopters). In the example, it is 11.5 diopters.



As the crystalline lens of a human ages, the crystalline lens proteins, known as alpha **crystallins fall out of solution or precipitate**, the lens becomes cloudy, and **cataracts** are formed. The crystalline precipitates scatter blue light out of the eye so that objects appear more yellowish. At this point the crystalline lens can be replaced with a synthetic intraocular plastic lens.

In 1940, Harold Ridley noticed that when Fighter Lt. Gordon “mouse” Cleaver was shot down in his Hurricane in combat, his eyes were filled with slivers of Perspex (Poly(methyl methacrylate)) that were not rejected by the body’s immune system. Ridley realized that the body’s tolerance to Perspex, as well as its mechanical and optical qualities, would make Perspex a good artificial intraocular lens material. The medical establishment thought that such an operation was too risky, so in 1949, Harold Ridley performed the first lens transplant in secret. Currently intraocular lens are made of softer material such as silicone and acrylic, making it possible to insert the intraocular lens through a tiny incision.



The **iris** is the colored part of the eye and we will talk about its color next week. The **iris** contains **circularly-arranged sphincter and radially-arranged dilator muscles**. Contraction of the sphincter muscle, which is a striated muscle, **closes the pupil** in response to stimulation by the parasympathetic nervous system, which is active when the body is in the **rest and digest state**. Contraction of the dilator muscle, which is a smooth muscle, **opens the pupil** in response to stimulation by the sympathetic nervous system, which is active when the body is in the **fight or flight state**.

Oxytocin, which is produced by the human body during sexual arousal, also causes pupils to dilate. Eckhard Hess discovered the role of pupil size in communicating attitude. The size of the pupil lets people know our emotional state.

We can mimic emotional states in terms of pupil size with drugs, such as **atropine (belladonna)**, hysocyamine, and scopolamine that cause dilation of the pupils known as mydriasis by inhibiting the parasympatheitic nervous system. **Opiates** mimic the rest and digest state by inhibiting the sympathetic nervous system and causing an extreme contraction of the pupils known as miosis.

Typically, the adult human pupil is about 2-3 mm in diameter and children have larger pupils than adults. The adult human pupil varies from 2 mm in bright light to 8 mm in dim light.

Demonstration: Perform the flashlight test to see your classmate's pupils contract in bright light and dilate in dim light. Both pupils respond the same way, even if you only illuminate one. This **consensual response** indicates that there is higher-level control of pupil size. Also notice that the pupils constrict when your

classmate's pupils go from looking at a distant object to looking at a near object. Did you also notice that your classmate's eyes turn in when going from looking at a distant object to looking at a near object? **Accommodation** is a **global process** that is always accompanied by constriction of the pupils and converging of the eyes. Note that a dilated pupil at night will allow the light of a distant star to hit more rods!

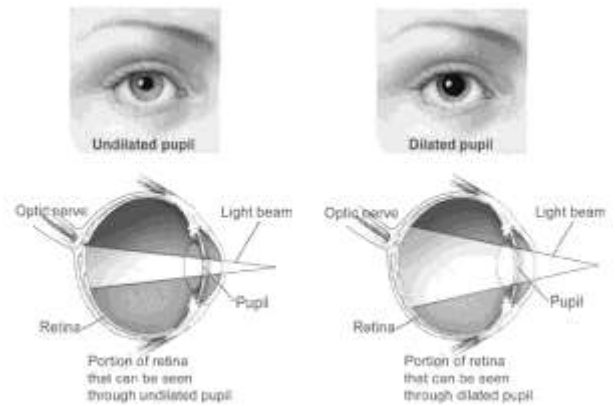

The closing of the human pupil is probably not important in reducing the intensity of light that enters the eye since the area of the pupil varies over a ratio of 16:1 while the eye works efficiently over an intensity ratio of 100,000:1. The closing of the pupil probably functions to limit the rays of light to the central part of the lens, which is the optically best part of the lens that gives maximal acuity, except under low light conditions when the full aperture is needed for maximal light sensitivity (Land and Nilsson, 2012).

The **iris** and **pupil** allow the amount of light that enters the eye to vary much like the **aperture diaphragm of a camera** lens varies the amount of light that reaches the film. The **f-stop** of the eye varies from f/8.3 to f/2.1. A larger aperture favors a brighter image with greater spatial resolution, more aberration and less depth-of-field, while a smaller aperture favors a dimmer image, with less aberration and more depth-of-field. Perhaps children have larger pupils because their young refracting elements have fewer aberrations.

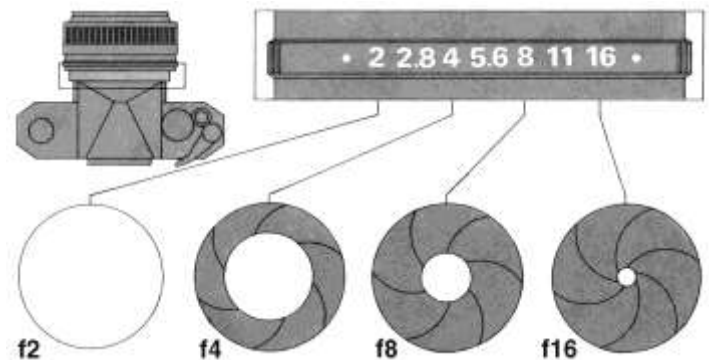

The human eye is a sphere approximately **one inch** in diameter. Most of the eye is surrounded by the **sclera**, which is about 1 mm thick. The word **sclera** is derived from the Greek word for “hard.” The tough and hard sclera protects the eye. It is the body part that was immortalized at the Battle of Bunker Hill when Israel Putnam or William Prescott yelled, “*Don’t fire till you see the whites of their eyes,*” reminding the soldiers not to waste gunpowder when the enemy was not close enough.

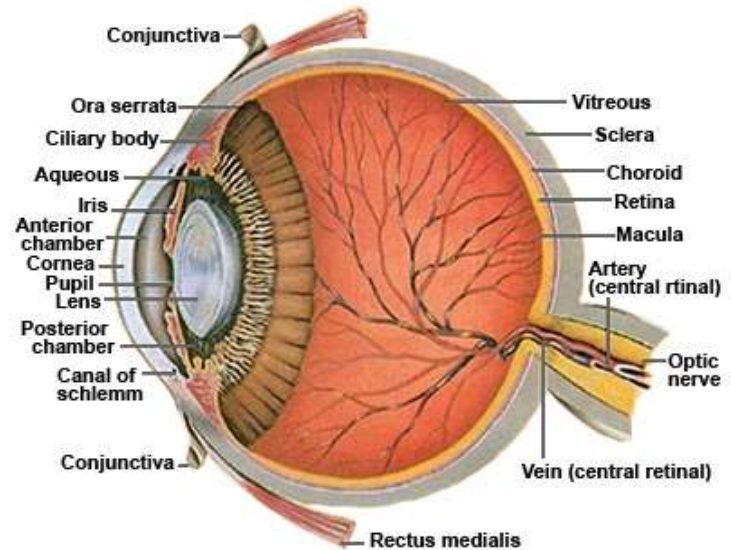

The white part of the eye (sclera) and the inner surface of the eyelid are covered by a membrane, known as the **conjunctiva** that contains blood vessels. Infection of the conjunctiva results in conjunctivitis, commonly known as **pinkeye** (left). Blood can also accumulate in the region between the conjunctiva and the sclera (right). This is known as a subconjunctival hemorrhage and can also be caused by high blood pressure, chemicals, or trauma.



The sclera is covered with **fatty tissue** that insulates the eye from mechanical shock. The sclera also is connected to three pairs of **extraocular muscles** that move the eye up and down, side to side, and to rotate the eyes to counteract head movement. Cows only have four muscles that move the eyes up and down and side to side. **Nerves** innervate these muscles to tell the brain which direction each eye is looking. Information is passed to the brain concerning the **convergence angle** described as the angle each eye turns to look at the same object when the image in each eye is projected on the **fovea** of the **retina** in each eye.

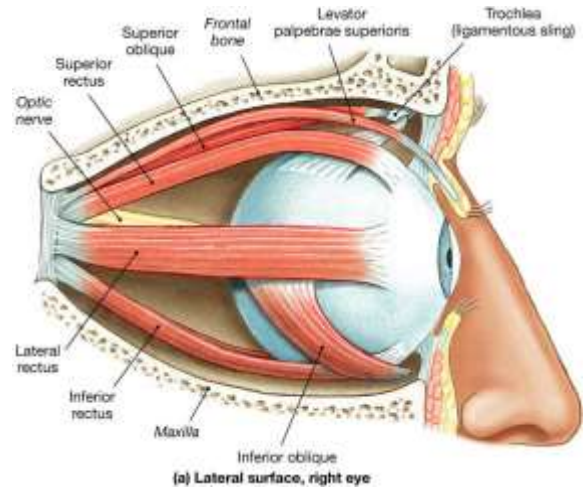

The **choroid** is the layer inside the sclera that contains blood vessels that nourish most of the tissues of the eye and remove wastes.

We will dissect a cow or pig eye to understand the anatomy of a human eye:

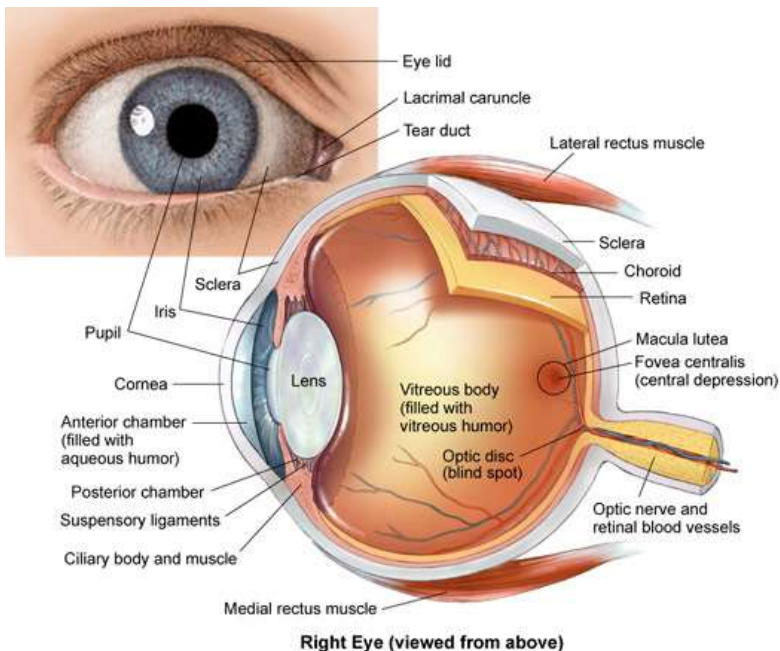

Dissection of cow eye

The parts of the eye we will see are labelled below:

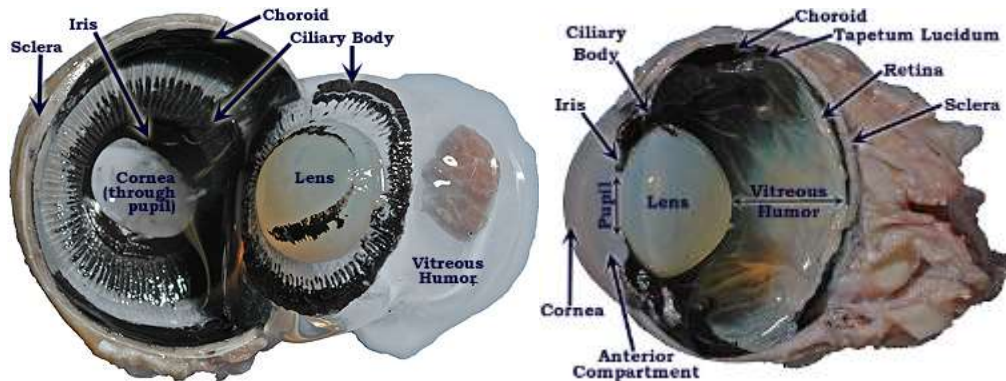

Put on gloves that fit, and get a scalpel, scissors, a tray and an eye. If necessary, remove with the scissors, the fat and the muscles that are attached to the sclera. In the back of the eye, you should see the optic nerve that transmits the visual information to the brain.

Use the scalpel to cut through the sclera at the middle of the eye. Then use the scissors to cut all around so that the eye separates into the anterior and the posterior halves. Hopefully you will have disturbed neither the ciliary body nor the retina. You will see the **crystalline lens**, the **ciliary body**, the **iris**, the **pupil** and the **cornea** in the front half and

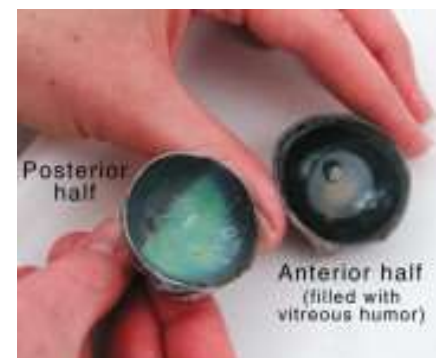

the **retina** and the **tapetum** in the back half. The vitreous humor fills the cavity. Bits of cellular debris in the vitreous humor, known as floaters, are the cause of faint shadows on the retina.



Hold the front part of the eye and look through it to get a **cow's eye view of the world**.

Turn the front half of the eye so that the back of the **crystalline lens** is facing up. (The picture is of the top facing up). The crystalline lens is held in place by the **ciliary body** which contains muscles that contract in order to increase the dioptric power of the crystalline lens and we can see nearby objects in focus.



When the muscles of the ciliary body relax, the crystalline lens becomes flatter, which decreases the dioptric power of the crystalline lens and we can see distant objects in focus.

Remove the crystalline lens from the ciliary body. Is the crystalline lens converging or diverging? Is the image real or virtual? How can you tell?



Look through the crystalline lens. The lens is a double convex converging lens that produces an inverted, real image of an object that is more distant than its focal length. The crystalline lens produces an erect, virtual image when the object is closer than the focal point. The elastic properties of the crystalline lens cause it to round up and take the form of an accommodated lens when it is separated from the zonal fibers and the ciliary body. Feel how elastic the crystalline lens is.

Demonstration: Cut a sliver from the crystalline lens and carefully place it on the pin of the **Leeuwenhoek microscope replica**. As you are looking through the pinhole in the window or at the clear blue sky, adjust the specimen height so that the top edge of the specimen is in the middle of the lens and then adjust the distance of the specimen from the lens until the specimen is in focus. Can you see the **fibrous layers of the crystalline lens** like Leeuwenhoek did? Is the lens in the Leeuwenhoek microscope replica converging or diverging? Is the image formed by the microscope real or virtual? How do you know?

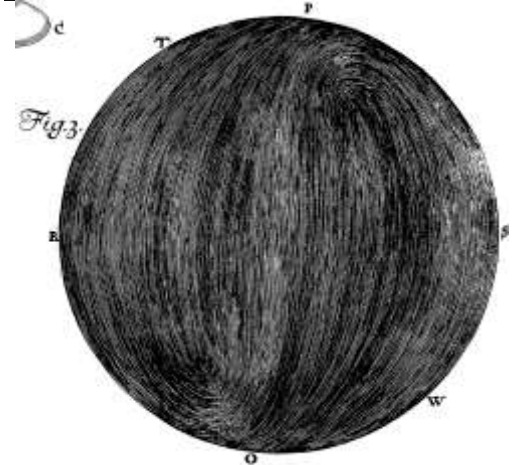

Push back the ciliary body and find the **black elastic iris** and the **oblong pupil** whose major axis is horizontal. The pupil regulates the amount of light that enters the eye. When the pupil contracts, it reduces the amount of light, reduces the amount of aberrations, increases the depth of field, and reduces the resolution, just like the iris diaphragm in the pinhole camera. Grazing animals,

like the cow, tend to have horizontal pupils. Since the pupil of the cow is greater in the horizontal direction, the cow can resolve horizontal details more sharply than it can resolve vertical details. Humans, with a round iris, see details equally sharply, independent of their orientation. Remove the iris and look at the **cornea**. The cornea is relatively thin; neither delicate nor tough. Imagine doing Lasik surgery on it!

Now look at the back half of the eye. The retina is a very soft tissue, typical of neural tissue.



The retina is somewhat goeey. The retinal ganglion cells pass through the **optic disc** to connect to the optic nerve. The **optic nerve** is very shiny because of the high lipid content of the **myelin sheath** that surrounds the neurons.

Humans have a melanin containing pigmented layer in the back of the eye to absorb any photons that are not absorbed by the photoreceptor pigments in order to **minimize any glare** that would come from stray light. On the other hand, it is hard for us to see at night because humans do not have a mirror-like **tapetum lucidum**.

Animals including, cows, pigs, raccoon, dogs and cats have a mirror-like tapetum lucidum that reflects light that was not

absorbed the first time back to the retina so that they can see better in the dark.

Although the tapetum lucidum enhances the ability to see in the dark it makes the image less sharp since the light from a single object point is reflected to nearby photoreceptor cells. The reflection of light from the tapetum lucidum is responsible for the glowing eyes of animals seen in dim light.

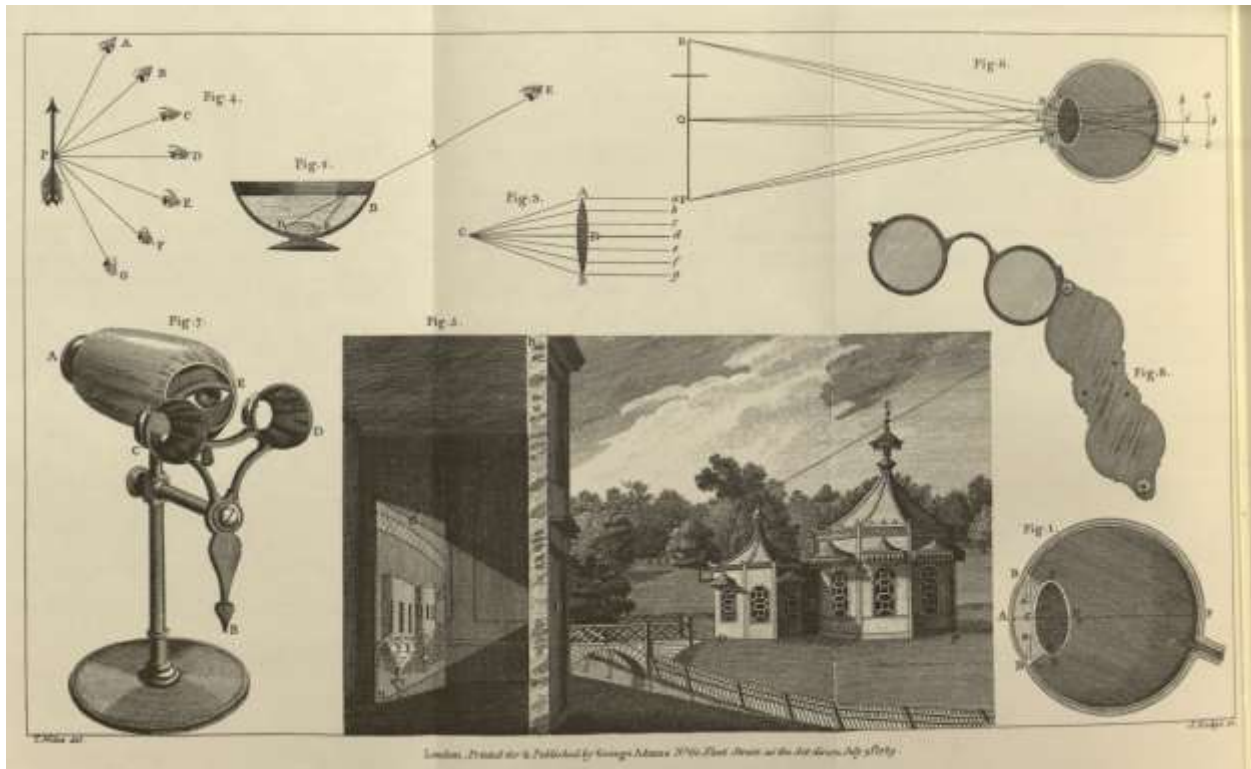

The eye is a simple and elegant instrument. George Adams (1789, 1792), the instrument maker to King George III, wrote in his *An Essay on Vision*, “*In the structure of the eye we find the most evident manifestations of exquisite art and design, every part elegantly framed, nicely adjusted, and commodiously placed, to answer in the most perfect manner every possible good purpose, and thus evince that it is the work of unerring wisdom, prompted to action by infinite love. So manifold are the blessings we derive from this organ....To it we are indebted for that delightful sensations that arise from the proportion and variety of forms, the harmonious mixture of colours, and the graces of beauty. It enables us to seek, to see, and to chuse our food; to go here and there, as the calls of friendship, or the occasions of business, require; to traverse the ocean, ransack the bowels of the earth, visit distant regions, accumulate wealth, and multiply knowledge. Assisted by it, we become acquainted with the works of the Creator, and can trace his wisdom, his power, and his goodness, in the texture of plants, the mechanism of animals, and the glories of the heavens.*”

Percy Shelley wrote in his *Hymn of Apollo*:

*I am the eye with which the Universe
Beholds itself, and knows it is divine;
All harmony of instrument or verse,
All prophecy, all medicine, is mine,
All light of art or nature; - to my song
Victory and praise in its own right belong.*